

# The Mercedes-Maybach S-Class



Mercedes-Benz



# The wealth of independence.

Maintaining the tradition of the legendary brand for top-class luxury vehicles, we are redefining the ultimate in luxury like never before. Step on board and experience an unparalleled combination of exclusivity, innovation and excellence.



A symbol of modern aesthetics and  
luxurious spaciousness.

Poise and assurance characterise the unique design, underscored by the mighty chrome radiator grille with “Maybach” lettering and the bonnet trim strip at the powerful front end. All round the vehicle, a host of other chrome details gleam to superb effect, perfectly complemented by the legendary two-tone paint finish if desired.





The focus is always on your well-being and comfort.

We are continually developing new ideas for innovative and exclusive comfort in the rear. Among the latest ideas are the comfort doors that open easily at the touch of a button. Or the very obliging seat belt feeder that reaches out to help you. Meanwhile, over long distances, the calf massage and heated neck cushions make the journey all the more enjoyable.

## Ready to assist you at any time.

The vehicle's surroundings are now monitored even more precisely and with greater foresight, so that many dangers can be reduced from the outset. From DIGITAL LIGHT to the extended Driving Assistance Package and rear airbags, the new generation offers a further boost to confidence.





Experience inspiration and first-class feel-good comfort in the rear compartment.

Move the Executive seat to a comfortable position. Be inspired by the electric centre console and the MBUX Interior Assistant, and control the various comfort and entertainment functions. Enjoy the variety offered by the MBUX high-end rear seat entertainment system or work in relaxed style with the MBUX rear tablet.



## Unique rear view with exceptional recognition value.

The two-part tail lights with animated functions are a fascinating new design element that contributes to the high value appeal and unmistakable night design. They harmonise with the front and side views of the top model in the Mercedes-Benz passenger car fleet to provide the perfect finishing touch to this masterpiece.



## Active driving noise compensation.

Innovative driving noise cancellation can help ensure that irritating tyre noise is left behind, making the Mercedes-Maybach S-Class an oasis of calm. Whether in town or on long journeys, you only hear what you really want to hear via the optionally available Burmester® high-end 4D surround sound system.

## MBUX Interior Assistant in the rear.

Intelligent and intuitive: the MBUX Interior Assistant in the rear has eyes only for you and can recognise many of your wishes based on your natural movements. Enjoy a driving experience in a class of its own, where you can sit back, relax and still have many things under control without having to do more than raise your hand.

## MANUFaktur backrest trim in wood.

The backs of the front seats feature MANUFaktur wood trim elements in a colour coordinated with the rest of the interior and sport the “Maybach” emblem, further enhancing the ambience in the rear and visually underscoring the vehicle’s hand-crafted character.

## Enjoy a fantastic ambience.

The interior is finished to stunning effect with exclusive materials in superb quality. An important component here is the leather upholstery with the brand-typical seat upholstery layout in a diamond design. This exceptional quality is complemented by other surfaces in the interior, which are upholstered in leather according to the specific configuration.





## Ambient lighting.

Showcase the interior according to personal preference or simply your current mood. The 64 colours of the ambient lighting create exciting colour schemes, which can alternate dynamically or illuminate individual areas in different colours – and include the two Maybach light colours twinkle star and rosé gold.



## Burmester® high-end 4D surround sound system.

Enjoy music as a unique 4D experience. Eight exciters, rather like loudspeakers, in the seats unfold this new sound dimension with a sound massage. Some 30 high-end surround speakers, also integrated in the seats, and a subwoofer optimise the surround sound up to a total output of 1750 W.



## MBUX augmented reality head-up display.

The MBUX augmented reality head-up display makes the windscreen part of the digital cockpit. Transparent projections onto the windscreen augment the driver's field of vision with relevant information about the current driving situation.



## Discover the age of intuitive ease of use.

The combination of 3D cockpit display, MBUX head-up display with augmented reality in the front windscreen and central OLED touch display represents an innovative and at the same time intuitive control concept. Thanks to MBUX voice control, the vehicle can adapt to your requirements and support you.

## Exclusive Package.

Enjoy the fantastic ambience provided by the Exclusive Package. Almost all surfaces are finished in exquisite nappa leather, the roof liner in high-quality DINAMICA microfibre. This exceptional high-class appeal is perfectly supplemented by additional trim elements.

## High-End Interior Package.

Experience a level of automotive luxury that verges on perfection. Electric comfort doors provide access to your First-Class rear suite, where you will be enraptured by the amazing audio quality of the Burmester® high-end 4D surround sound system. Innovative features such as the active ambient lighting and the MBUX high-end rear seat entertainment system create a sophisticated atmosphere.

## Parking Package with 360° camera.

Exclusive parking service with all-around visibility: Active Parking Assist with PARKTRONIC and 360° camera detects available parking spaces as you drive past. After selecting a parking space, you can park in it effortlessly thanks to dynamic visualisation and acoustic feedback – or have the vehicle manoeuvre into the space with the help of assisted parking.

## Rear Seat Comfort Package.

Optimum seating comfort in the rear: the multicontour seats impress with more than an ideal seating position. A range of massage programs ensures that they can also have a revitalising or relaxing effect. Similarly, the heating system for the neck and shoulder area that is integrated into the additional cushion is a real boon.





## AIRMATIC.

AIRMATIC combines the advantages of several suspensions in one – choose between comfort and dynamism. The set-up range is particularly impressive. The air suspension offers outstanding ride comfort even on challenging roads, or powerfully sporty performance. Practical: the level control system based on the vehicle load.



## A unique drive program specifically for the passengers in the rear.

The specially developed “Maybach” drive program focuses entirely on ride comfort for the passengers in the rear, while the COMFORT drive program offers balanced ride comfort for front and rear passengers. With the “Maybach” program, care has been taken to ensure that the sprung mass vibrations felt in the rear seats are kept to a minimum. Other settings include an extra-flat throttle curve in chauffeur mode, transmission tuning with fewer shifts, and starting in second gear.

# Dimensions.

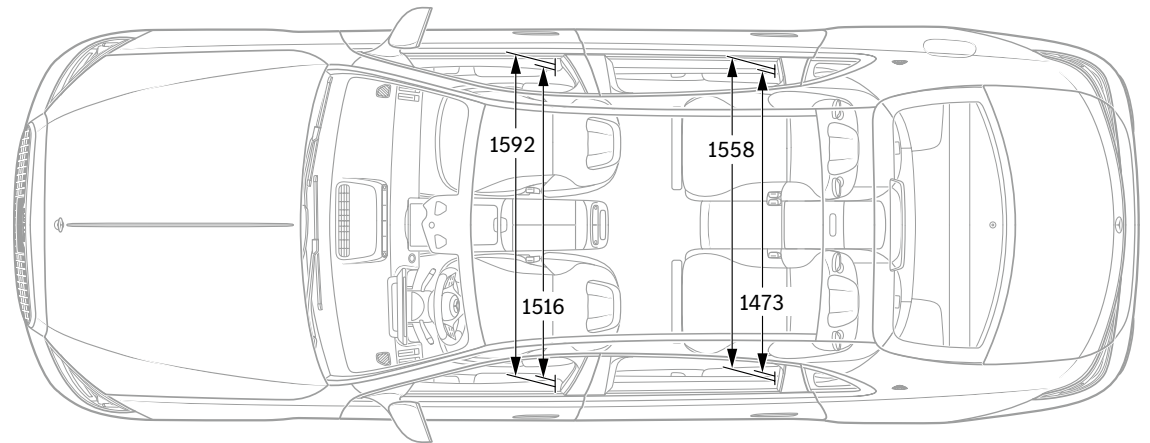
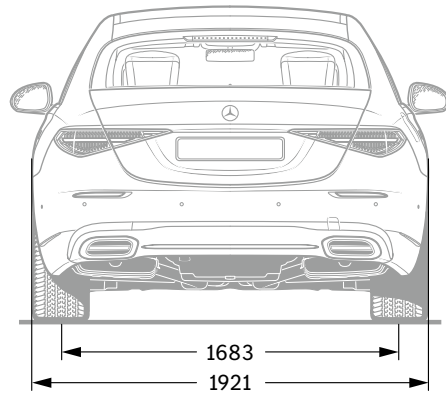
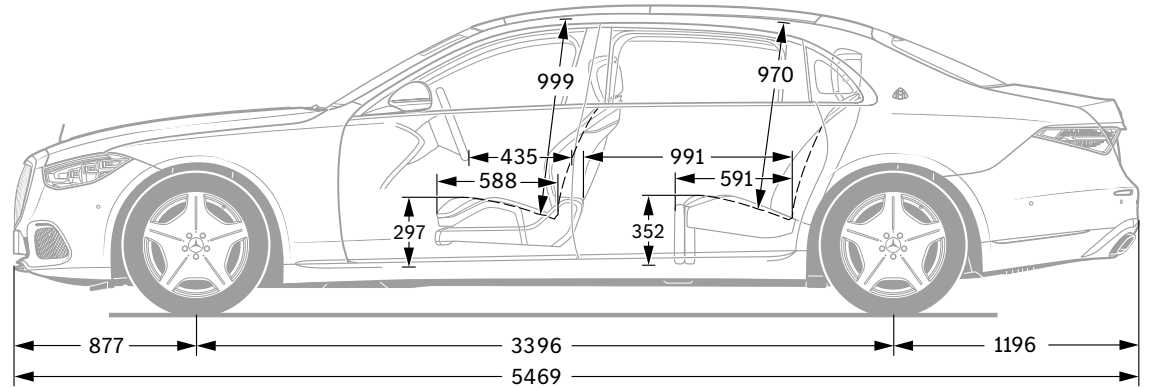
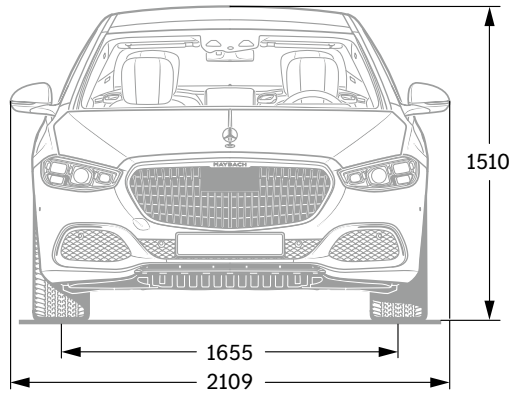

All figures in millimetres. The dimensions shown are mean values. They are valid for vehicles with standard equipment and in unladen condition.