



MERCEDES-MAYBACH GLS

MAYBACH



THE VERY BEST. FROM THE VERY BEST.

The design of the Mercedes-Maybach GLS embodies the ultimate in luxury. Typical Maybach elegance meets the characteristic dominance of an SUV. The generous dimensions of the exterior ensure an appearance befitting its image. Intelligent technologies and properly thought-out details are the finest form of comfort: With its generous interior, the Mercedes-Maybach GLS provides a first-rate oasis of peace.





TRAVEL FIRST CLASS.

The Mercedes-Maybach GLS offers plenty of reasons to toast with champagne. Fittingly, there is space for a refrigerated compartment between the two rear seats. You can add authentic silver-plated champagne flutes to the equipment. The Mercedes-Maybach-specific diamond quilting, stylish upholstery colours and high-quality seat upholstery of the Mercedes-Maybach GLS emphasise the exclusivity of the interior. With the four-seater featuring First-Class rear compartment, you always have your mobile wellness spa with you: you can set yourself a comfortable lying position at the touch of a button.

BRILLIANT LUXURY. SHINES BY DESIGN.

The striking rear lamps and the high-gloss chrome-plated, Maybach-specific tailpipe trims with horizontal insert on the Mercedes-Maybach GLS exude a superior exclusivity and ensure a presence befitting the car's status.



A GRAND APPEARANCE.

The new front design with the updated radiator grille and the engraved Maybach lettering as well as the classy front bumper is impressive. The exclusive Mercedes-Maybach emblems in the air intakes are another highlight.





FIRST-CLASS COMFORT MEETS HIGH CLASS.

Intelligent technologies and properly thought-out details are the finest form of comfort: with its spacious interior, the Mercedes-Maybach GLS provides a first-rate oasis of peace. The high-quality seat upholstery as well as the typical Mercedes-Maybach diamond quilting set individual accents. The modern steering wheel not only steers the vehicle, it also permits convenient operation of a host of functions, from navigation to entertainment.



DOING NOTHING IS THE TRUE LUXURY.

The specially developed MAYBACH drive program "Maybach" is focused solely on driving comfort. Among other things, it ensures low body movement on the rear seats, a flat accelerator pedal characteristic and gearbox tuning with fewer gearshifts.



Exemplary safety with Mercedes-Benz Intelligent Drive systems.

In the rush hour, during a long drive at night or on unfamiliar roads, your Mercedes-Maybach GLS can noticeably take the strain out of driving, particularly in stressful situations. It's all down to a concept that makes every journey in a Mercedes-Benz a safer and very special experience: Mercedes-Benz Intelligent Drive¹. Because the time you spend behind the wheel is your time. Time for relaxation. Time to replenish your energy. So that, first and foremost, you not only reach your destination safely but also do so more relaxed.

¹Our driver assistance and safety systems are aids and do not relieve you of your responsibility as a driver. Please note the information in the Owner's Manual and the system limits which are described therein.



Mercedes-Benz User Experience.

Experience luxurious comfort with all your senses: the Mercedes-Benz User Experience takes operating convenience to a whole new level – with every look, every word and every touch. The innovative Widescreen Cockpit responds to voice, gestures or touch input and guarantees a fascinating operating and display experience.



Ambient lighting in the roof liner.

Showcase the interior according to your personal preferences or current mood. With a total of 64 colours, the ambient lighting offers almost unlimited scope for lighting schemes and has the right colour for every situation. The all-round lighting conveys a heightened sense of security, especially in the rear.

Electrically extending running boards.

The electrically extendable and illuminated side running boards with Maybach emblem ensure a firm tread when entering and exiting the vehicle and emphasise a refined appearance.

Legroom.

Freedom is not having to restrict oneself: the Mercedes-Maybach GLS offers rear passengers plenty of legroom and a recline of up to 43.5 degrees. On every journey, this means you can just sit back, enjoy and relax.

MBUX High-End Rear Seat Entertainment System.

Enjoy first-class entertainment: via two high-resolution, fully integrated 11.6-inch displays. Even in the rear, this gives you the full MBUX experience with direct access to vehicle functions.



Acoustic Comfort package.

Enjoy an exceptionally low level of noise while on the move. The sound insulation of the Acoustic Comfort Package significantly reduces disruptive exterior noise. There is thus nothing to stand in the way of relaxed conversations, even when driving at high speeds. The quiet atmosphere also promotes concentration, enabling you to arrive relaxed at your destination.

Driving Assistance Package.

The Driving Assistance Package¹ offers maximum comfort and safety on the road to autonomous driving and turns your Mercedes-Benz into a thinking partner. One highlight is the Active Stop-and-Go Assist function, which can significantly relieve stress when driving on the motorway in stop-and-go traffic.

Surround lighting with animated projection.

A function which appeals to your emotions. When the doors are open, the ambient lighting uses sophisticated LCD technology to project an animated Mercedes-Maybach pattern onto the ground in the front and rear entry areas, which is then conveniently illuminated. The presentation of the brand logo is a real eye-catcher.

AIR BALANCE Package.

The AIR BALANCE Package delivers a fascinating experience for the senses and promotes your well-being. In the Mercedes-Maybach GLS you can expect the light floral fragrance of “No. 8 Mood”. The composition is centred around the white osmanthus flower – rounded off with a delicate hint of leather and spiced tea. Alongside the pleasant fragancing, the package contributes to enhanced air quality on board.

¹Our driver assistance and safety systems are aids and do not relieve you of your responsibility as a driver. Please note the information in the Owner's Manual and the system limits which are described therein.

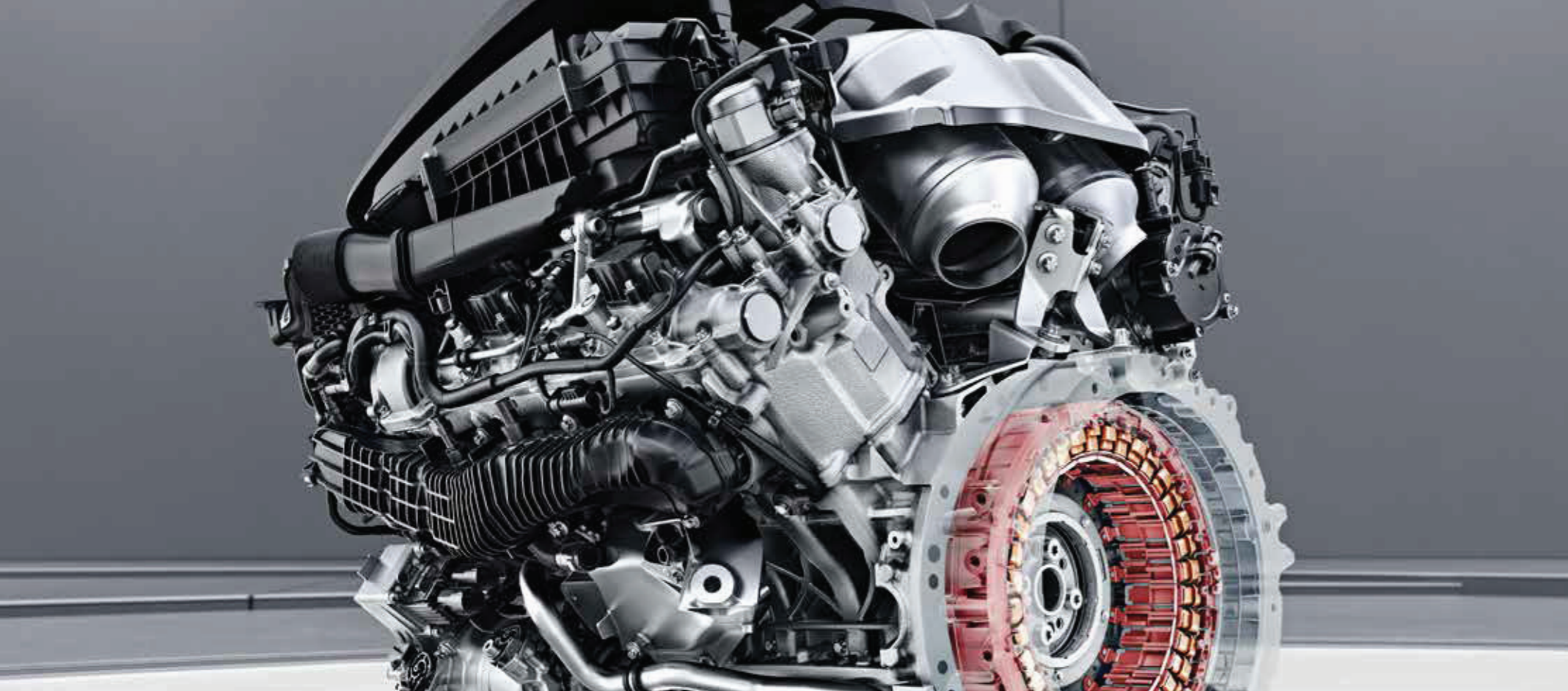

Partially electrified V8, the Maybach among the engines.

The V8 drive system in the Mercedes-Maybach GLS is propelled to outstanding levels of power and efficiency by additional electrification in the form of a starter-alternator.

¹ Figures for rated output and rated torque pursuant to Regulation (EC) No. 715/2007 in the currently applicable version.



E-ACTIVE BODY CONTROL.

Superior ride comfort in any situation: E-ACTIVE BODY CONTROL is the synthesis of comfort, precision and dynamism – combined with unique off-road qualities. Experience the first-class effects of a modern, fully active suspension designed to compensate for pitch, roll and shocks. On all roads and off the road. In both good and bad driving conditions.

Dimensions.

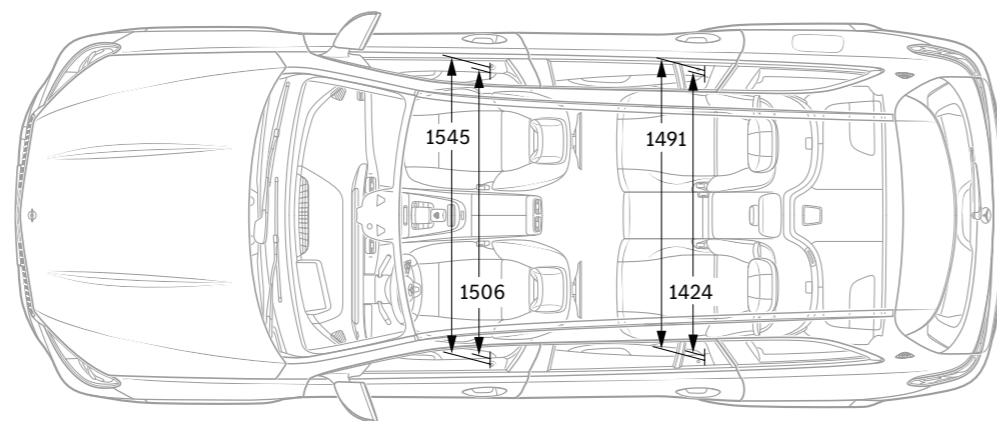
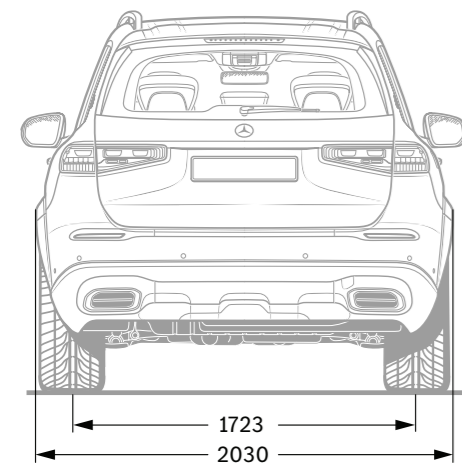
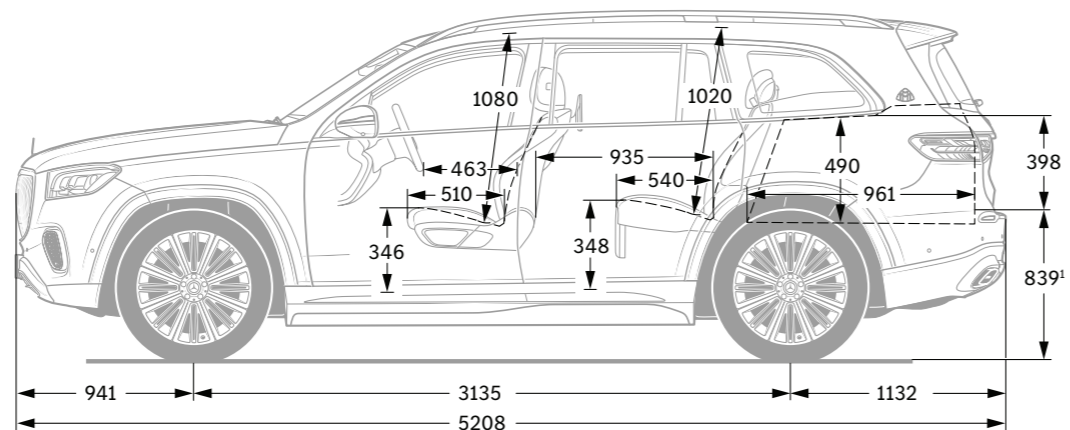
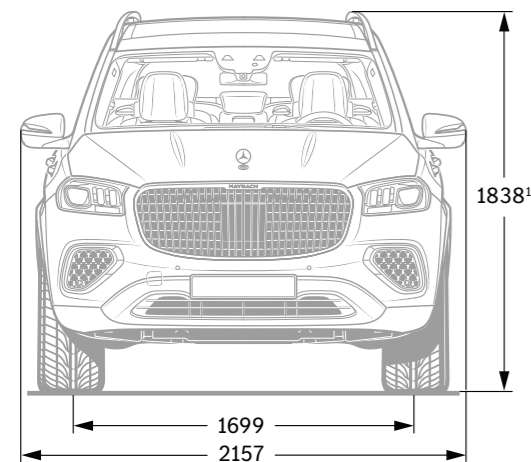

¹With suspension set to "On-Road". All figures in millimetres. The illustrated dimensions are mean values. They are valid for vehicles in basic specification and in unladen condition.