



THE MERCEDES-MAYBACH
EQS SUV

MAYBACH





WELCOME TO BEYOND.

An innovation that sets standards. The first all-electric SUV with the luxury and comfort of a Maybach. Typical Maybach exclusivity in the electric era: the new Mercedes-Maybach EQS SUV meets the highest expectations. A new chapter in electric mobility – in the top luxury segment.

Mercedes-Maybach EQS 680 SUV | WLTP: electric energy consumption in kWh/100 km (combined): XXX-XXX;
CO₂ emissions in g/km (combined): 0.¹

¹The electric energy consumption and range were determined on the basis of Regulation (EU) 2017/1151.

IMPRESSIVE APPEARANCE.

Hallmark of exclusive luxury: the Mercedes-Maybach EQS SUV impresses with its typical Mercedes-Maybach radiator grille, including “Maybach” lettering and an upright Mercedes star on the bonnet. Leading the way: the revolutionary DIGITAL LIGHT headlamps with projection function not only visually enhance the driving assistance systems while the car is on the move, but also welcome and say farewell to you with a Maybach-specific logo projection.





ANYTHING BUT ORDINARY.

The aerodynamically optimised shape of the Mercedes-Maybach EQS SUV boasts details such as flush-fitted door handles, the Maybach roof spoiler and an elegant rear aspect. For a distinctive appearance, there is a choice of exclusive 2-tone paint finishes, plus LED tail lamps in a 3D helix design with an animated light strip. A truly exclusive vehicle: the Mercedes-Maybach EQS SUV ensures all-electric driving with unprecedented elegance.

Mercedes-Maybach EQS 680 SUV | WLTP: electric energy consumption in kWh/100 km (combined): **XXX-XXX**;
CO₂ emissions in g/km (combined): 0.¹

¹The electric energy consumption and range were determined on the basis of Regulation (EU) 2017/1151.



THE BIG-SCREEN EXPERIENCE.

Among the highlights for front occupants is the standard-fit Hyperscreen with zero-layer technology, together with the latest-generation MBUX system (NTG7). The large, curving screen unit gracefully extends across almost the entire dashboard, providing personalised entertainment, numerous new functions and means of interaction – controlled intuitively by voice or touch. There are also Maybach-specific start-up animations on all three displays.



FIRST CLASS IN EVERY SEAT.

Innovative materials and outstanding technologies make the interior of the Mercedes-Maybach EQS SUV a haven of comfort. The lighting themes of the ambient lighting, exclusive Maybach interior trim and high-end entertainment system make for the perfect lounge atmosphere. Also available on request are extended comfort features and relaxing First Class rear seats, which can be adjusted to a comfortable reclined position at the touch of a button.



CONNECTED AND PERSONALISED.

The MBUX high-end rear seat entertainment system that is included as standard makes the Mercedes-Maybach EQS SUV a truly multi-faceted experience. Whether you're looking to pass the time or attend to work, the high-resolution touchscreens with direct internet access and multimedia system ensure full digital convenience. And thanks to the intelligent MBUX system, the vehicle adapts itself to your individual needs. It can remember your favourite music, store your usual seat positions or automatically set the desired temperature.

EXCLUSIVE ENTRY.

The outstanding luxury of the vehicle is noticeable as soon as you open a door. The logo projections on the ground, together with illuminated running boards with the Maybach emblem, provide for a distinctive first impression.



CHARGING HAS NEVER BEEN AS UNCOMPLICATED AS THIS.

Intelligent charging comes to your home: with the powerful AC charging system, you can charge at up to 22 kW (3-phase)¹. Charging processes can easily be controlled and viewed via the Mercedes me App². Mercedes me Charge³ allows access to one of the world's most extensive charging networks. Easy charging, even across national borders, or at IONITY fast-charging stations. The next ideal charging stop? Already planned by Navigation with Electric Intelligence.

¹ 22 kW charging may require the appropriate optional equipment "AC charging system (AC charging 22 kW)", depending on the manufacturer and vehicle concerned. The Mercedes-Maybach EQS SUV supports up to 22 kW as standard. ² The Wallbox incorporates the pre-installation for Remote Functions. In order to use the Remote Functions of the Mercedes-Benz Wallbox you will need the Mercedes me App and a personal Mercedes me ID, and must give your agreement to the Terms of Use for the Mercedes me connect services. ³ In order to use the Mercedes me connect service "Mercedes me Charge", you will require a separate charging contract with a selected third-party provider via which the charging processes are billed and paid for. The use of Mercedes me connect services requires a personal Mercedes me ID and agreement to the Terms of Use for the Mercedes me connect services.



Luxury on four wheels.

Conceived for luxury from stem to stern. You have a choice of two sizes for the exceptional wheels of the Mercedes-Maybach EQS SUV: 53.3 cm (21 inches) or 55.9 cm (22 inches). Black-painted wheel arches with striking claddings elegantly round off the exterior.



Special lighting concept.

Travel in more relaxed style: the ambient lighting heightens your sense of wellbeing on a journey by providing the ideal lighting mood for any situation. Configure the lighting from the headliner to behind the rear seats to suit your preference or current mood. A total of 64 colours gives you numerous lighting moods to choose from.



Sustainably processed leather.

The Mercedes-Maybach EQS SUV is the first Mercedes-Benz model to feature leather tanned using vegetable tanning agents. This sustainably processed material is produced using resource-conserving methods. The tanning process uses coffee bean husks and water, which are reprocessed and returned to the natural cycle.

The Burmester® high-end 4D surround sound system with sound personalisation.

The Burmester® high-end 4D surround sound system with sound personalisation features the immersive Dolby Atmos audio experience, giving your music more space, clarity and depth. Dolby Atmos makes it possible to place discrete audio elements or objects in a three-dimensional sound field and adapt them to any playback environment.

The multifunction steering wheel in Maybach-design nappa leather.

The latest-generation Maybach-specific multifunction steering wheel in nappa leather combines luxury with an innovative ease of operation in a way that is more intuitive than ever. Ergonomically arranged Touch Control buttons allow the intuitive control of mobile phone, speed, entertainment, navigation and driver assistance systems.

MAYBACH drive program.

In addition to the DYNAMIC SELECT drive programs ECO, SPORT, OFFROAD and INDIVIDUAL, the Mercedes-Maybach EQS SUV includes the special MAYBACH drive program. This replaces the classic COMFORT program and is designed to provide maximum ride comfort for the rear passengers. It ensures that only minimal body movements occur under the rear seats.



AIRMATIC.

The AIRMATIC air suspension offers an outstanding ride even over difficult ground. The level of the vehicle varies in line with the speed. This can increase the range when driving at speed. Practical: the automatic level control system based on vehicle load. At the touch of a button, you can also extend the ground clearance by up to 25 mm.



EVA platform architecture.

The Electric Vehicle Architecture of the Mercedes-Maybach EQS SUV allows for a broad spectrum of maximum total drive output. The vehicle features the fully variable electric 4MATIC all-wheel drive, which distributes the torque continuously between the front and rear axles according to the driving situation.

Dimensions.

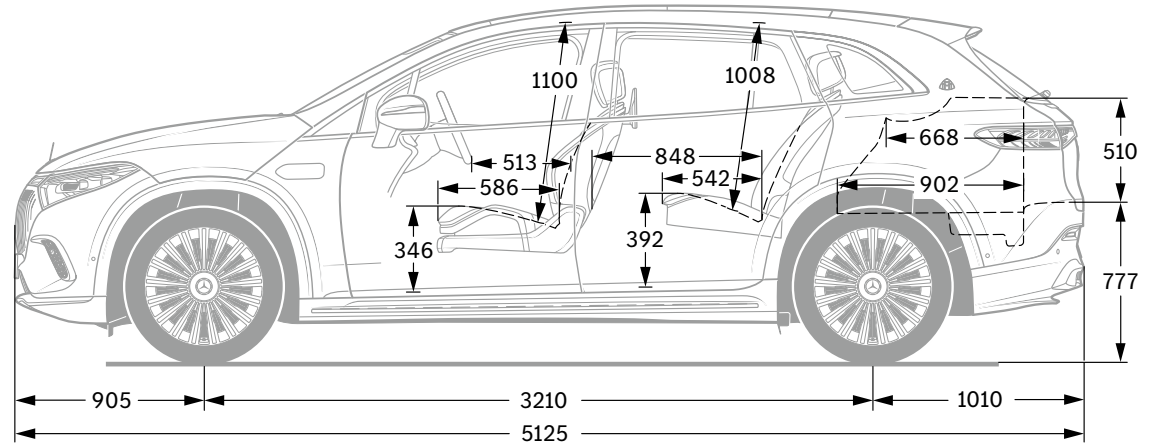
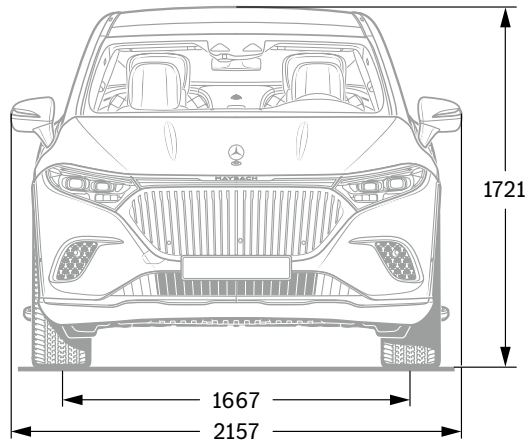

Vehicle length without licence plate adapter (2 mm).

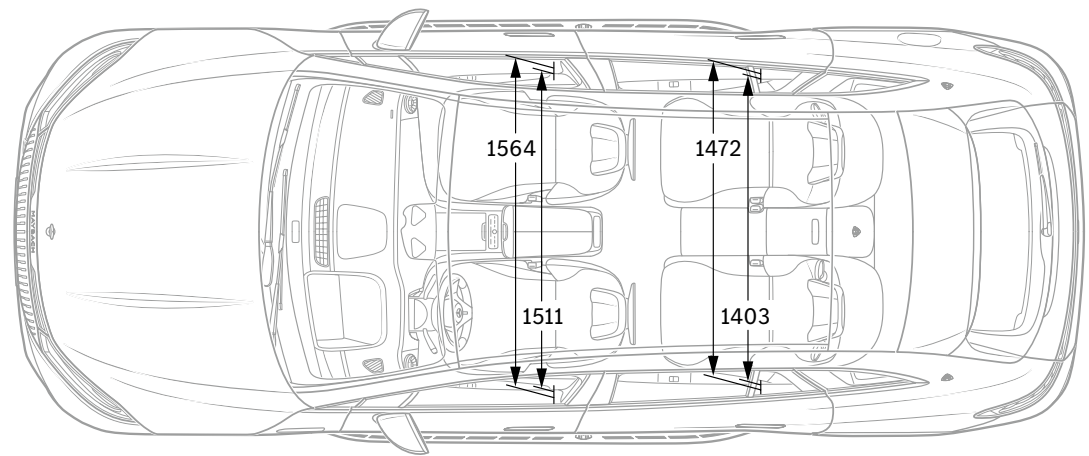
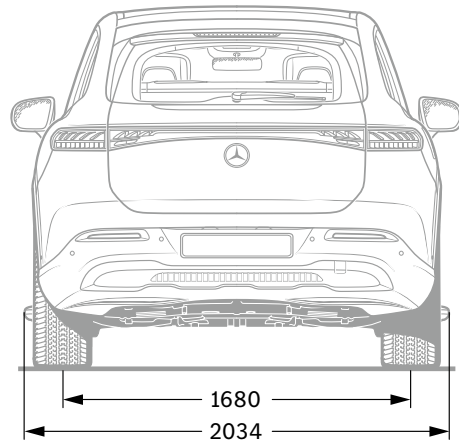

All figures in millimetres. The dimensions shown are mean values. They are valid for vehicles with standard equipment and in unladen condition.