

The GLE

Sport Utility Vehicle



Mercedes-Benz



A silver Mercedes-Benz GLE SUV is shown from a rear three-quarter view, driving on a two-lane desert road. The car is in the right lane, and a dark SUV is visible in the left lane ahead. In the distance, a railroad crossing with a 'RAILROAD CROSSING' sign and flashing lights is visible. The background features a vast, arid landscape with mountains under a blue sky with scattered clouds. The license plate on the silver SUV reads 'SUV 1670'.

The shape of success.
In a whole new dimension.

More intelligent and attentive than ever – the new GLE casts the SUV in a whole new light. Its suspension actively smooths out any unevenness and its infotainment system learns more about your preferences as the days go by. Its convenience systems, meanwhile, can recognise when you need to take a rest.



Consistency all down the line.

Take a step back at the right moment and then be right there when it matters the next moment – that is the art of the GLE design. Only the distinctive AMG Line and wheels up to 22 inches in size can make it sportier. This expression of clarity and dynamism is typical of Mercedes-Benz design today.



Follow your intuition.

The new GLE is the first SUV to feature the revolutionary MBUX infotainment system. Highlights here include a natural-language voice control system, a range of touch controls and the ability to learn more about the habits and preferences of the driver with each journey.



More space for inner greatness.

For the first time, the GLE is now available with a third seat row with two full-size seats. Access to the third row is easy, while the flexibility provided by an adjustable second seat row makes the footwell very adaptable. And what's even better is that the improved spatial concept of the new GLC still provides more legroom and comfort in the rear.



The embodiment of calm.

Keeping things calm can sometimes take a lot of effort. Under tricky circumstances, it's something achieved by only a few people and only one SUV: the new GLE with E-ACTIVE BODY CONTROL fully active suspension. It is able to adapt in a split second to the road surface ahead.



The new GLE simply
oozes serenity.

Sensual surfaces, muscular contouring and clear lines define the design of the new GLE. It is hard to imagine a more elegant and dynamic expression of power.



MBUX Augmented Reality for navigation.

Thanks to Augmented Video it is easier to find your way around the navigation environment. The sophisticated system facilitates orientation by linking the virtual and real worlds: graphical navigation instructions and traffic information are incorporated into live images. This helps you to get to your destination quickly and stress-free.

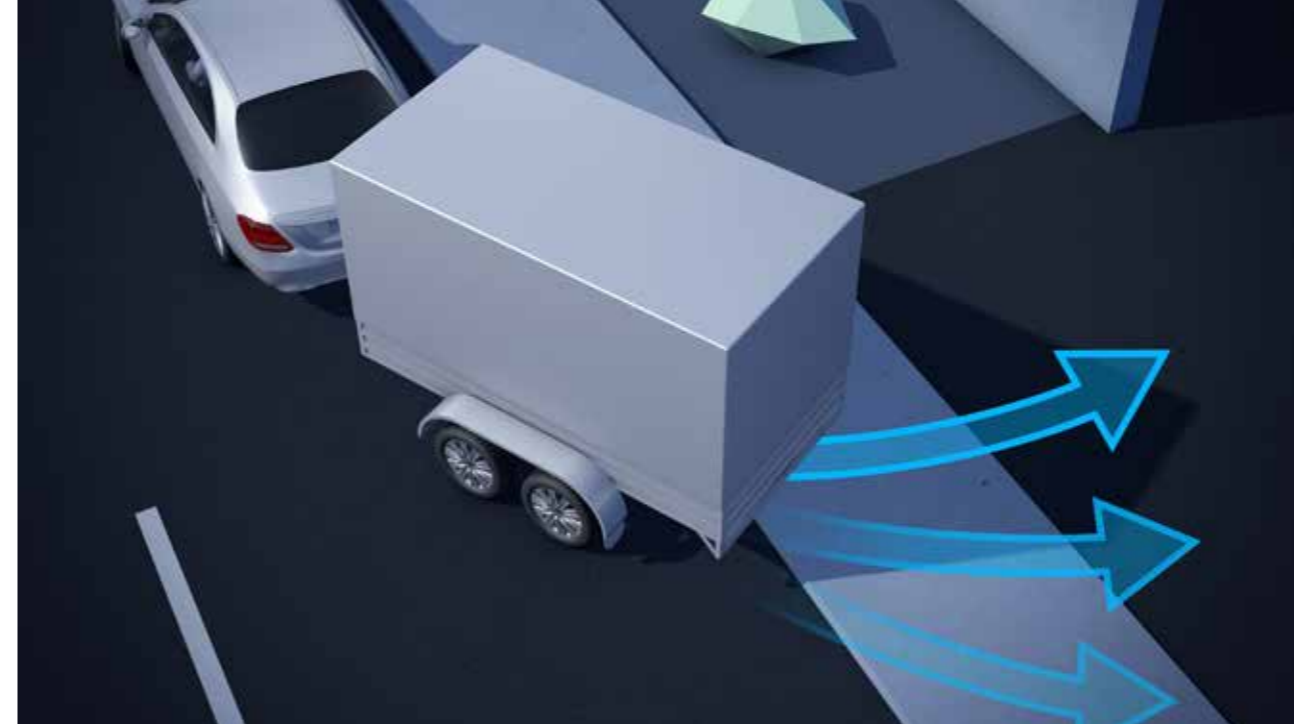

Trailer Manoeuvring Assist.

Save time and spare your nerves when manoeuvring: With the Trailer Manoeuvring Assist you can complete reversing manoeuvres calmly, confidently and precisely – even in difficult situations. For inexperienced drivers of car/trailer combinations in particular, the assisted steering is a genuine help.



ENERGIZING COACH.

The new optional ENERGIZING COACH can noticeably relax or invigorate the driver. For this purpose, it employs software which combines the data from a fitness tracker with various comfort systems in the vehicle.



Head-up display.

The best outlook for sporty driving enjoyment and an assured driving experience: the head-up display transforms your windscreen into a stunning digital cockpit. As such you always have a direct view of key information. Your full attention remains on the road and the traffic conditions in front of you.



Third seat row.

For the first time, the GLE is now available with a third seat row with two full-size seats. Access to the third row is easy, while the flexibility provided by an adjustable second seat row makes the footwell very adaptable.



Rear seats electrically adjustable.

The electrically adjustable second seat row brings a convenient level of flexibility: extend the load space at the simple touch of a button and position the rear seats as you require them. It all makes for a quick and easy way to create extra load capacity.



Widescreen Cockpit.

Design that impresses, right from the start: the elegant Widescreen Cockpit. And the more you explore, the better it gets: choose between various display styles, follow the navigation guidance provided by MBUX Augmented Reality, position the displays as you want them. All on two large 31.2 cm (12.3-inch) displays under a stylish glass cover.



Burmester® high-end 3D surround sound system.

An audio experience comparable with that of a top-end home music system. Loudspeakers within the roof liner compose a three-dimensional sound. You conduct the system as if it were your personal orchestra – with VIP settings for specific seats or stylistic requests such as “Live” or “Easy Listening”. Perfection in design and engineering: the extendable tweeters.

Standard equipment and appointments.

Powerful vehicle with powerful character: the exterior conveys strength and elegance. Its generous proportions exude poised assurance and a sense of safety.

The progressively styled interior represents the epitome of sporty elegance. Generous dimensions, high-quality materials and numerous practical details provide the basis for a luxurious ambience and genuinely comfortable travel.



The AMG Line equipment line.

The optional AMG Line adds a shine with a sparkling diamond radiator grille. Sporty aprons all round, large air inlets, painted wheel arch liners and special light-alloy wheels demonstrate sporting style.

AMG Line features add a touch of racing style to the interior and support dynamic driving.



EXCLUSIVE interior.

The EXCLUSIVE interior allows you to show what's important to you: exceptional elegance and first-class quality in every tiny detail. The luxurious highlights and refined ambience of your interior will bring a smile to your face every day anew.

Night Package.

Added character – expressive style. In combination with the AMG Line, the Night Package adds striking highlights in the form of exclusive black design features. These accentuate the sporty character and athletic design idiom of your vehicle. Ideal for individualists with a true appreciation of expressive design.





Driving Assistance Plus Package.

The optionally available Driving Assistance Plus Package tangibly reduces the strain on the driver, particularly on long trips but also in confusing urban traffic. The new GLE is available with the very latest generation of this package, which can now provide support in even more driving situations: for example in a traffic jam or in advance of bends,

roundabouts or junctions. The new GLE can now even follow the vehicle in front autonomously in stop-and-go traffic. This also relieves the driver of the bothersome task of restarting after each stop.

E-ACTIVE BODY CONTROL fully active suspension.

With the new E-ACTIVE BODY CONTROL fully active air suspension we are pooling our most innovative and intelligent suspension technologies to create a mesmerising driving experience.

In “Curve” mode, the vehicle can actively lean into a bend. This minimises the transverse force and tangibly increases comfort and dynamism. In “Comfort” mode, the ROAD SURFACE SCAN with stereo camera scans the road ahead of the vehicle¹. The suspension struts are then activated so as to substantially reduce the body movements when driving over bumps in the road.

¹ In conjunction with the Driving Assistance Plus Package.

Dimensions.

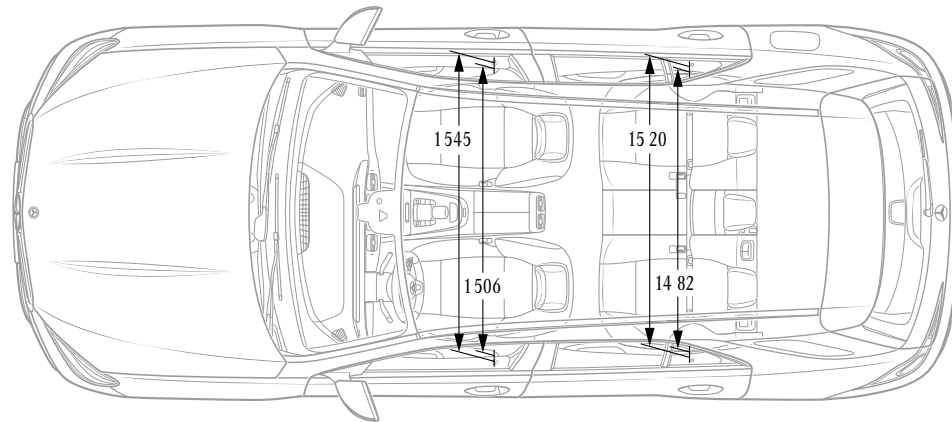
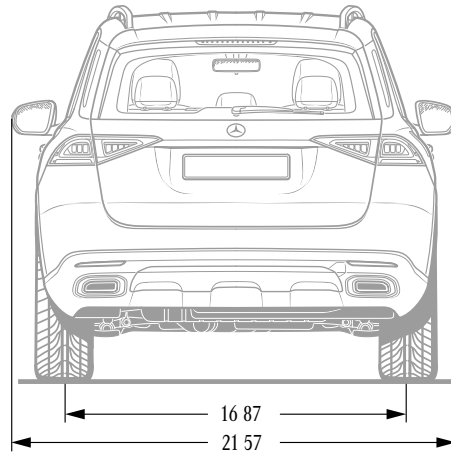
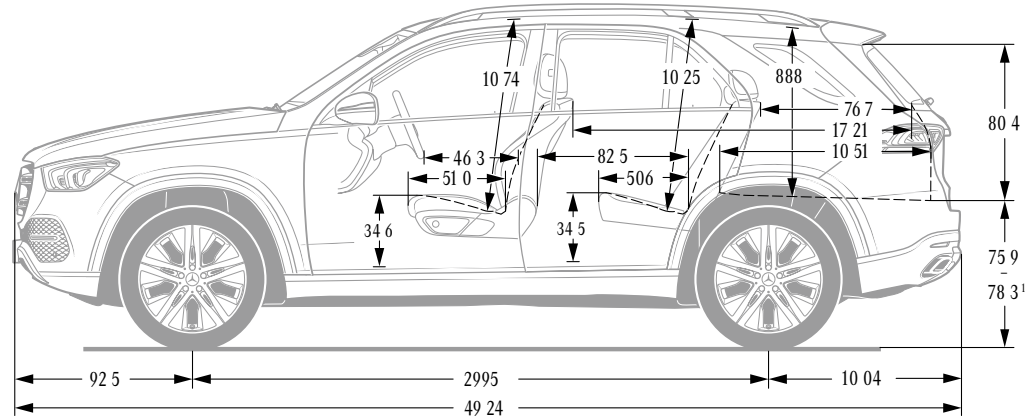
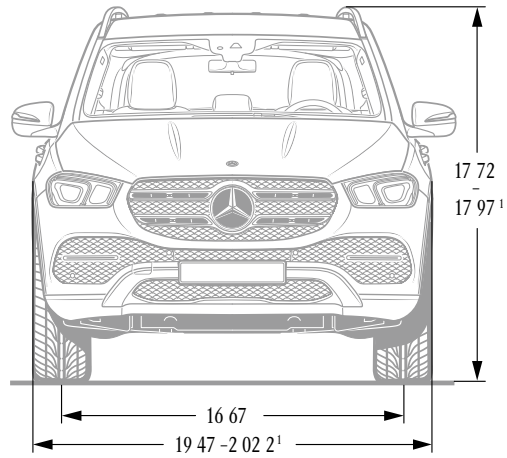

¹ At minimum to maximum height with steel suspension. All figures in millimetres. The illustrated dimensions are mean values. They are valid for vehicles in basic specification and in unladen condition.